

THE
BEDDER WAY CO.®
Handcrafted Murphy Beds

INSTALLATION INSTRUCTIONS -HORIZONTAL BEDS-

BEFORE YOU BEGIN, PLEASE TAKE A FEW MOMENTS TO FAMILIARIZE YOURSELF WITH ALL OF THE PARTS AND CONFIRM THAT ALL OF THE HARDWARE IS INCLUDED. ALSO, READ THESE INSTRUCTIONS THOROUGHLY BEFORE STARTING THE ASSEMBLY AND INSTALLATION.



FAILURE TO PROPERLY SECURE THE BED TO THE WALL CAN CAUSE SERIOUS INJURY! READ ALL SAFETY INSTRUCTIONS BEFORE INSTALLATION.

ASSEMBLY AND INSTALLATION REQUIRES TWO PEOPLE!

You will need to have these tools to install the wall bed:



Drill



**Phillips
Screwdriver**



Stud Finder



**1/8" Wood or Masonry
Drill Bit (per wall type)**



Ladder



3/8" Wood drill bit (for wood button plugs)













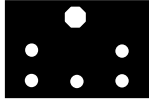

IMPORTANT SAFETY INFORMATION!

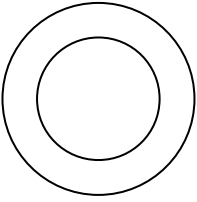

- It is extremely important that the bed be properly and securely affixed to the wall. Failure to do so can cause serious injury or death.
- The wall bed should be securely fastened to wall studs, concrete, block, brick or other wall type using the proper fasteners.
- When affixing the header to wall studs, the fasteners should be inserted into the center of the wall stud.
- The proper tools need to be utilized in installation of the bed. These are listed in the Installation Instructions.
- Installation of the bed should be performed by two people. Attempting to install the bed alone can cause injury.
- The wall bed should sit flush against the wall for secure installation.
- Never attempt to unscrew the wall bed from the wall while it is open.
- If you are using lighting, you should keep covers, comforters, and other bedding away from the bed when you close the bed. You should tuck any bulky bedding tightly between the mattress and the frame rails of the wall bed. Also, make sure no wires are being pinched at any location.
- Walls other than Wood Stud walls will require alternate fasteners (not provided) for installation. These may include molly/hollow wall anchors, toggle bolts (suggested for metal stud walls), Tapcons®, or other fastener types. Please consult your local home improvement store for recommendations.

HARDWARE INCLUDED

(Additional hardware/screws are included for beds with side cabinets and/or lighting kits)

Part	QTY.	Description	Color	Actual Size (most parts)
A	2	Pistons	Black	 (not actual size)
B	2	Upper Plates	Black	 (not actual size)
C	2	Pivot Pin Plates	Black	 (not actual size)
D	6	3/4" T-Nut	Black	
E	6	5/8" Machine Screw	Silver	
F	4	3/4" Wood Screw	Silver	
G	8	3/4" Wood Screw	Black	
H	2	5/8" Pan Head Screw	Silver	
I	2	Bed Stopper	Brass	1/2 SPHERE WITH RUBBER BUMPER
J	2	E-Clip	Black	 
K	2	Nylon Washer	White	
L	16	3/4" Cam Dowel	Silver	
M	5	3/8" Wood Plugs	Wood	
N	5	3" Wood Screw	Black	

HELPFUL HINTS:

- 1.) Unless you requested to have your wall bed without a notch for the base molding at the bottom of your wall, a 5 inch tall by 1 inch notch is included on your wall bed cabinet verticals. This is necessary for the wall bed to sit flush against the wall for a secure installation. If you ordered your wall bed without a notch because you want to make a different size notch, you should do this first, BEFORE any other step.
- 2.) Do not install any part with the unfinished sides or edges exposed. The unfinished side of a header should point to the ceiling; the unfinished side of a headboard should be against the wall, etc.
- 3.) If you ordered your wall bed **UNFINISHED**, there are some very important details to consider. They are as follows:
 - a. All pieces should be individually finished before you assemble the bed. You will not be able to completely finish all finished surfaces after assembly.
 - b. REMEMBER, the blocks on the outer face of the bed need to open and close. DO NOT finish the bed with the blocks in the closed position. Leave them open at a 45° angle during this process.
 - c. If you are applying paint to finish your wall bed, please make sure to prime all parts with a good quality primer before painting.
 - d. **DO NOT APPLY FINISHES TO THE PISTONS OR PIVOT PLATES!**
 - e. If you are staining and lacquering your wall bed, be sure to use a matching colored putty to fill any nail or screw holes PRIOR to your last coat of lacquer.
 - f. Always check to make sure all parts are completely dry before you assemble the wall bed.

The Cabinet Verticals are precisely machined for the parts you are about to install. Based on the machined holes in the Cabinet Verticals, you will very easily determine the location of the plates. The diagram also indicates the direction and position of these parts, as well as the proper fastener to use for each.

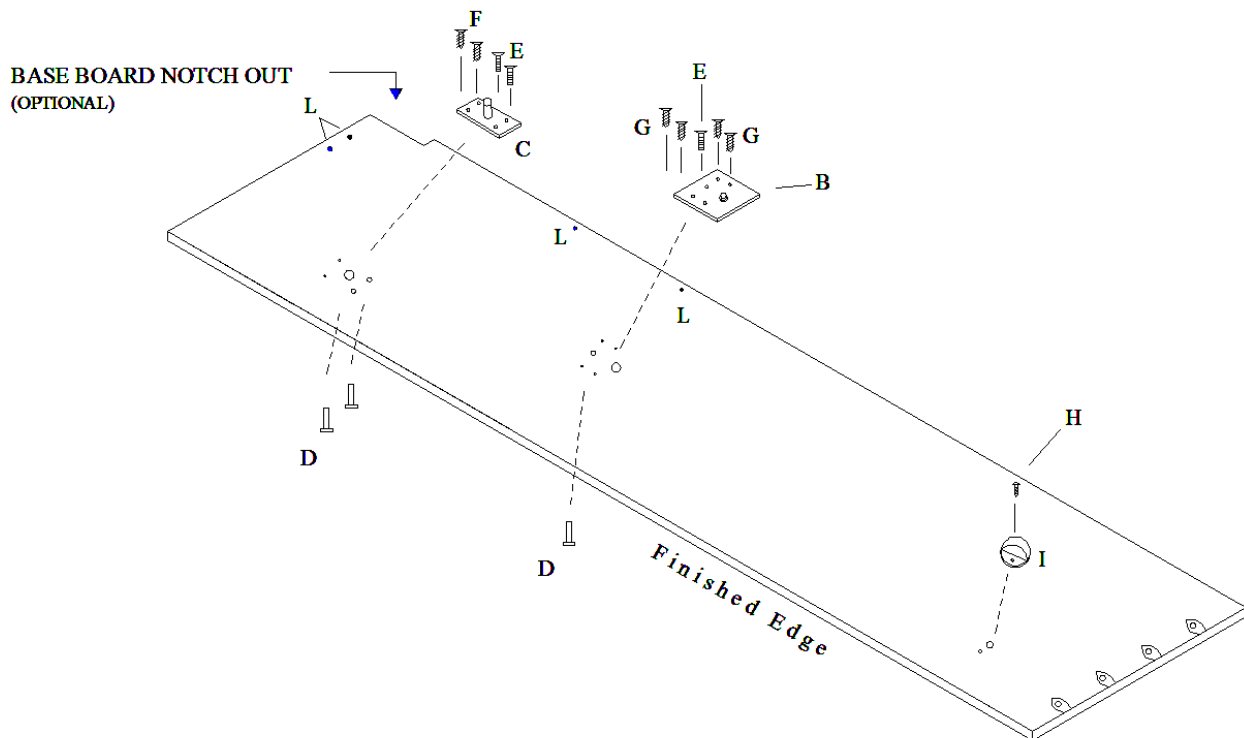

STEPS FOR INSTALLING PARTS ON YOUR CABINET VERTICALS

STEP 1: With one Cabinet Vertical lying on its side and several holes facing up, position one Upper Plate (**B**) with the nut on the back of the plate inserted into the upper most $\frac{3}{4}$ " hole. Insert a $\frac{3}{4}$ " T-Nut (**D**) in the through hole from the back side of the Cabinet Vertical. Insert a $\frac{5}{8}$ " Machine Screw (**E**) through the Upper Plate (**B**) and thread it into the $\frac{3}{4}$ " T-Nut (**D**). Finish by inserting four Black $\frac{3}{4}$ " Wood Screws (**G**) in the remaining holes. The pre-marked holes ease installation. REPEAT THIS STEP FOR THE REMAINING CABINET VERTICAL.

STEP 2: Position one Pivot Pin Plate (**C**) with the $\frac{1}{2}$ " end of the rod inserted into the lower most $\frac{3}{4}$ " hole. Insert two $\frac{3}{4}$ " T-Nuts (**D**) in the two through holes from the back side of the Cabinet Vertical. Insert a $\frac{5}{8}$ "

Machine Screw (**E**) through the Pivot Pin Plate (**C**) and thread into each of the $\frac{3}{4}$ " T-Nuts (**D**). Finish by inserting two Silver $\frac{3}{4}$ " Wood Screws (**F**) in the remaining holes. The pre-marked holes ease this installation. REPEAT THIS STEP FOR THE REMAINING CABINET VERTICAL.

STEP 3: In the four remaining holes, screw a $\frac{3}{4}$ " Cam Dowel (**L**) in each. Be sure to screw them in all of the way using a Phillips screwdriver, NOT A DRILL. Be careful not to over tighten them. REPEAT THIS STEP FOR THE REMAINING CABINET VERTICAL.

STEP 4: In the eight holes on the underneath side of the header (four on each side), screw a $\frac{3}{4}$ " Cam Dowel (**L**) in each. Follow the same installation directions as in **STEP 3**.

STEP 5: Position all of the parts approximately 24 - 36 inches from the wall where you plan to install the bed. Lay them out as shown below for ease of installation. You should use some padding if this is a hard surface.

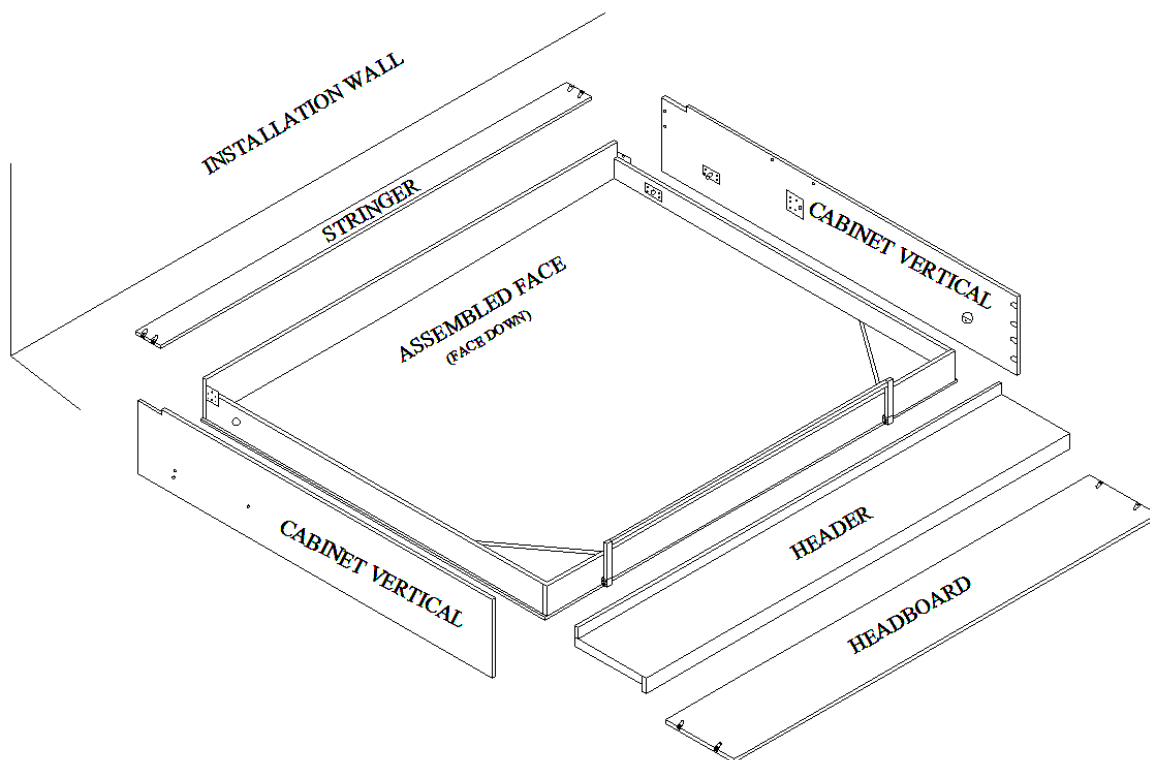

STEP 6: Place a Nylon Washer (**K**) on the Pivot Bar on each Pivot Pin Plate (**C**) and stand the Cabinet Verticals on their finished (front) edge.

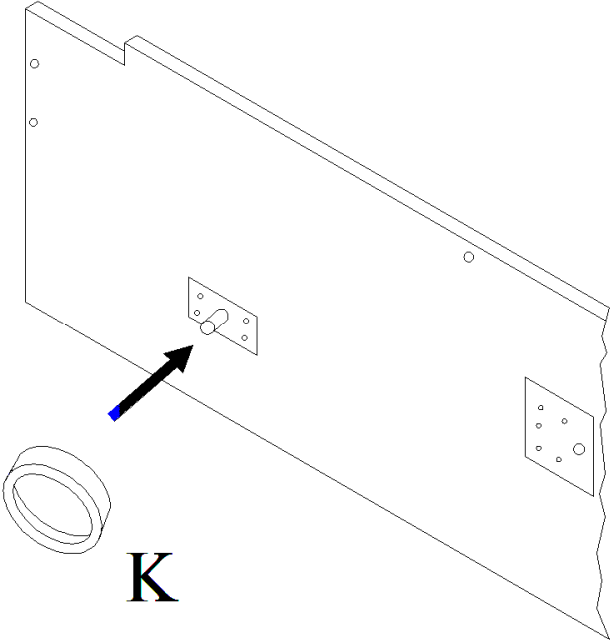

STEP 7: Slide the Pivot Bars all of the way into the Pivot Holes in the Assembled Frame. The Nylon Washer (**K**) will establish the spacing needed between these pieces.

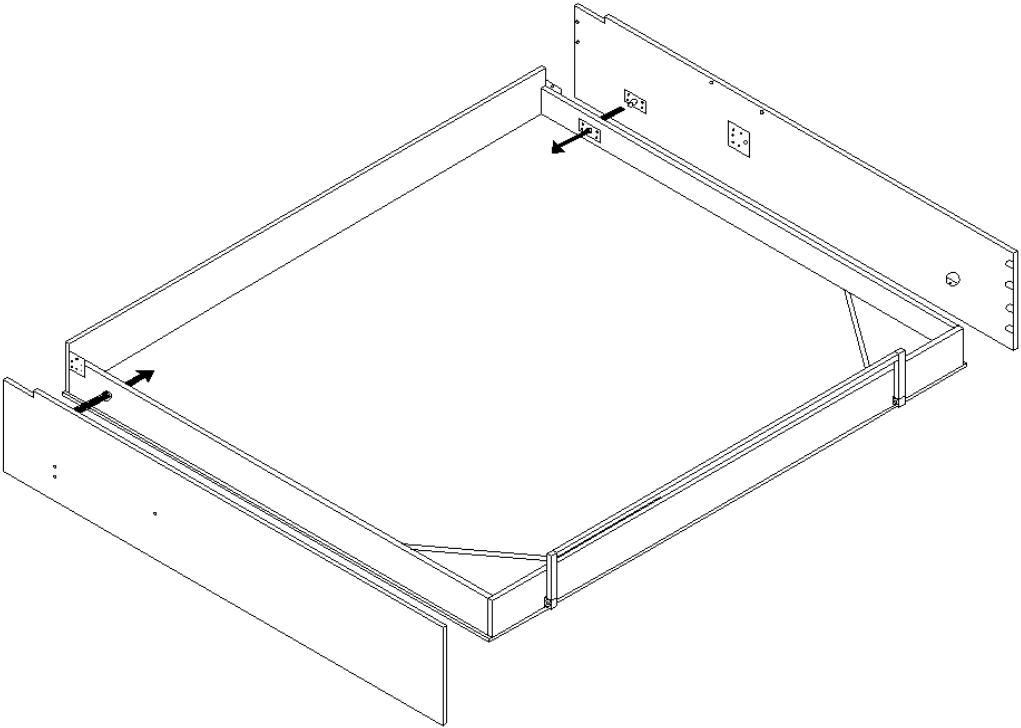

STEP 8: Snap one E-Clip (**J**) into the groove on each of the Pivot Bars locking the Cabinet Verticals to the Assembled Frame.

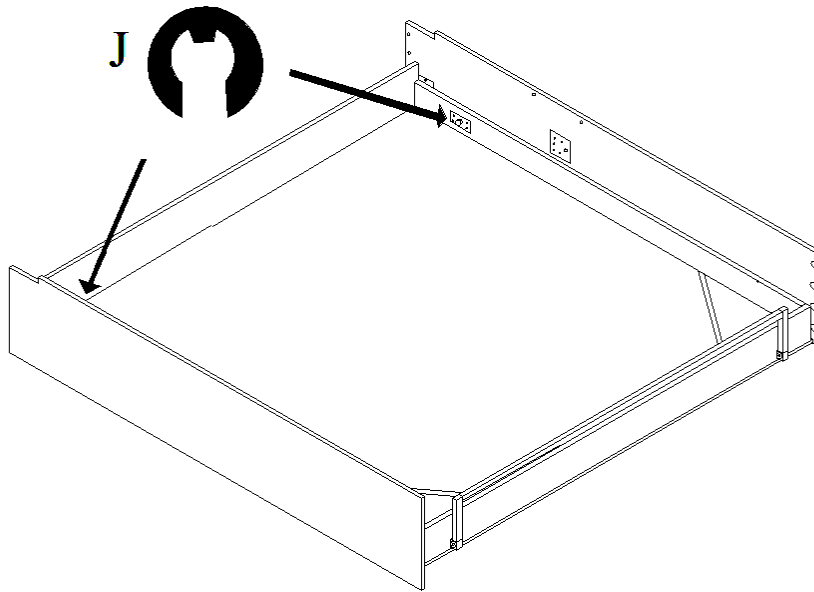

STEP 9: With the unfinished side of the Headboard facing up and the finished edge facing toward the top of the wall bed, attach the Headboard. Allow the Cam Dowels (**L**) to slip into the Cam Housings on each side. Secure the sides of the Headboard by tightening the Phillips head within each Cam Housing by using a Phillips screwdriver, NOT A DRILL. This is done by twisting the Phillips head approximately 120 degrees or until it is tight. Do the same to the other side. Make sure the Cam Dowel is fully seated in the Cam Housing.

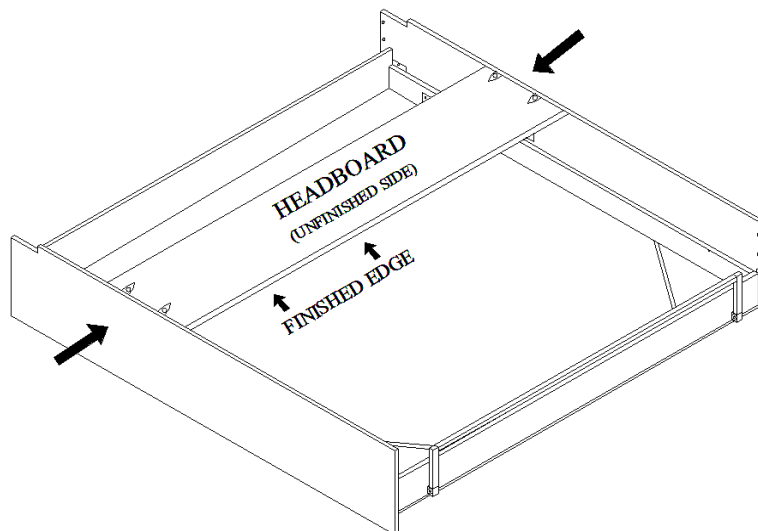

STEP 10: With the unfinished side of the Stringer facing toward the wall and the finished edge facing into the bed cabinet, attach the Stringer. Follow the same Cam fastening procedure as with the Headboard. (Notice this view is rotated 180 degrees from the view on the previous page)

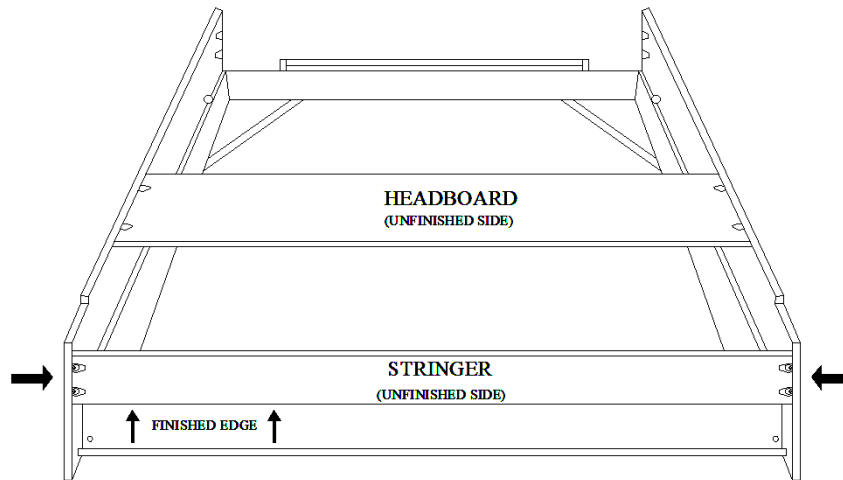

STEP 11: With the Assembled Face remaining face-down on padding, slowly and carefully, with two people (one on either side), rotate the Cabinet Verticals and Headboard to the upright position.

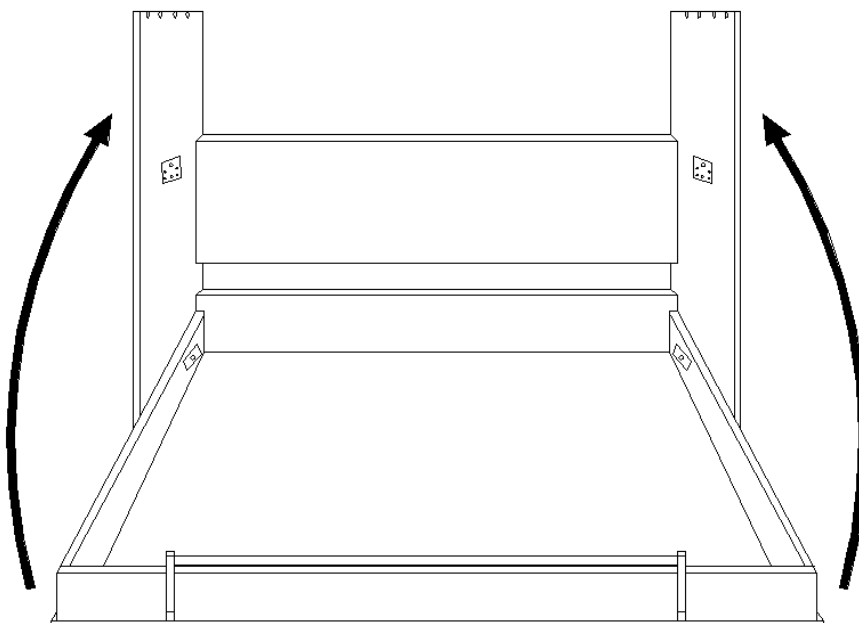

STEP 12: Place the Header on top of the Cabinet Verticals, making sure that the unfinished rear rail is at the rear of the bed and facing towards the wall and that the Cam Dowels (**L**) line up with the Cam Housings. This will also provide a lip on top of the bed for fastening the bed to the wall.

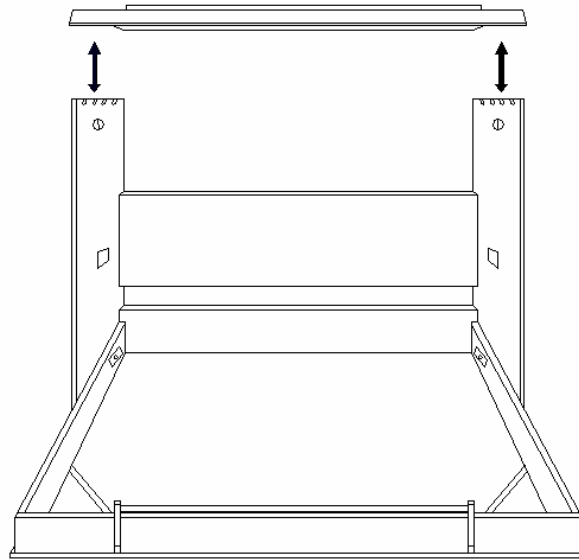

STEPS 13 AND 14: Fasten the Header to the Cabinet Verticals by tightening the Phillips head within each Cam Housing using a Phillips screwdriver, NOT A DRILL. This is done by twisting the Phillips head approximately 120 degrees or until it is tight. Do the same to the other side. Make sure the Cam Dowel is fully seated in the Cam Housing (4 on each side). Remove the Bed Stop (**I**) from each Cabinet Vertical before moving to **STEP 15**.

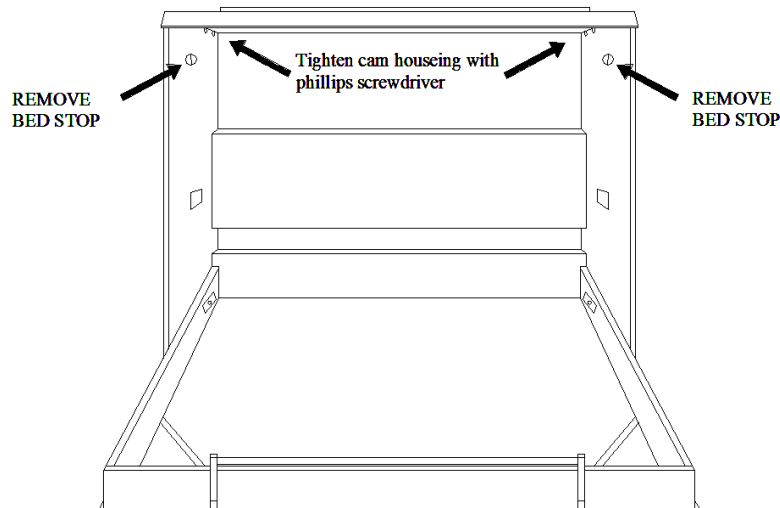

STEP 15: With a helper, lift the face of the bed. Have one person hold the face of the bed steady while the other person stands behind the bed with 2 Pistons (**A**). Allow the Assembled Face to recess back into the Cabinet Verticals about three inches. At this point, snap the smaller end of the Piston (**A**) on the ball receiver of the Lower Plate located on the Assembled Face. Be sure to orient the Pistons correctly by referring to the label and arrow ("MOUNT THIS END UP"). DO THIS ON BOTH SIDES. Finally, ON BOTH SIDES, snap the larger end of the Piston (**A**) onto the ball receiver on the Upper Plate (**B**) on the Cabinet Vertical. You may need to move the Assembled Face in and out slightly to perfectly align the ball receiver and the head of the Piston (**A**).

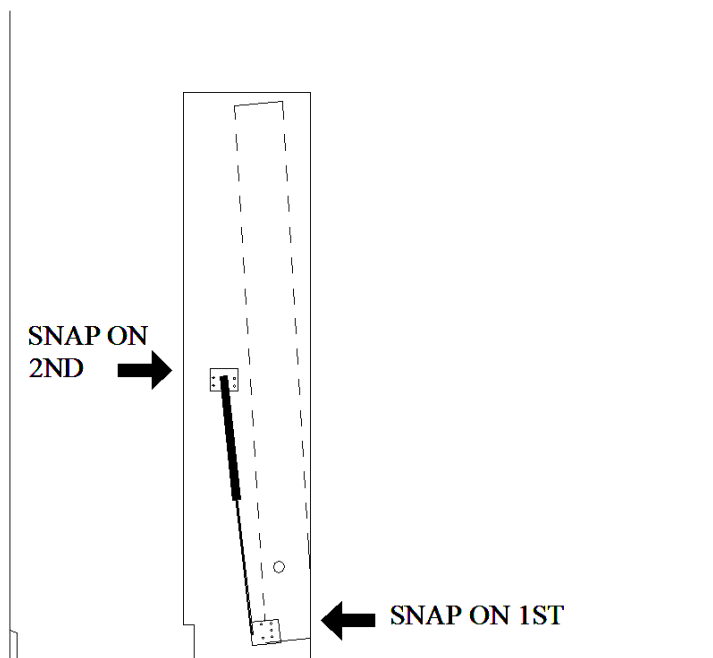

STEP 16: The person holding the bed face should now place one hand on the front of the header and gently pull the face out of the cabinet about 3 – 6 inches. The person behind the bed should then re-install one Bed Stopper (**I**) with the pin on the back inserted into the ¼" hole near the top of one of the Cabinet Verticals. Position the Bed Stopper (**I**) as to line up the hole with the pre-marked hole on the Cabinet Vertical. Secure this with a 5/8" Pan Head Screw (**H**). REPEAT THIS STEP FOR THE REMAINING BED STOPPER ON THE OPPOSITE CABINET VERTICAL.

STEP 17: Position the bed exactly where you want it on the wall, making sure that it is flush against the wall. By gently tapping the Cabinet Verticals (as needed) to the right or left, adjust the bed so that the gap between the Assembled Face and the Cabinet Verticals is equal all the way around.

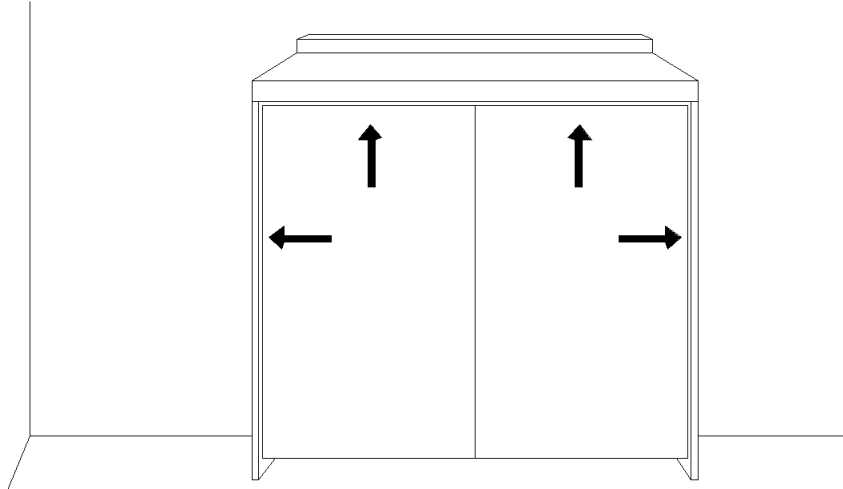

YOU ARE NOW READY TO MOUNT THE BED TO THE WALL!

STEP 18: Using an electronic stud finder and following the manufacturers instructions for use, locate the studs in the wall as shown. Mark an "X" to indicate the center of the stud. Locate as many studs as you can within this space (minimum of 3).

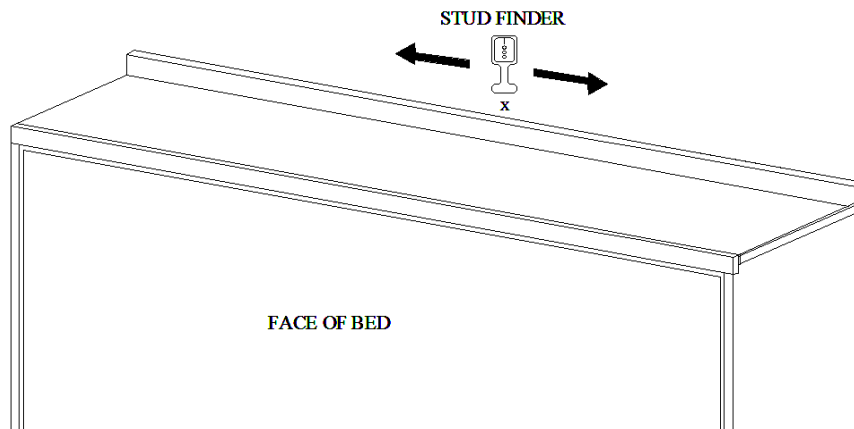

In the locations where you located and marked the center of the studs, **drill a 1/8" pilot hole** through the back rail of the Header. After you have drilled all of the pilot holes, use a **3/8" drill bit** and indent the pilot hole **1/4" deep**. Be careful not to drill deeper than indicated. These holes will accommodate the **3/8" Wood Plugs** in **STEP 19**.

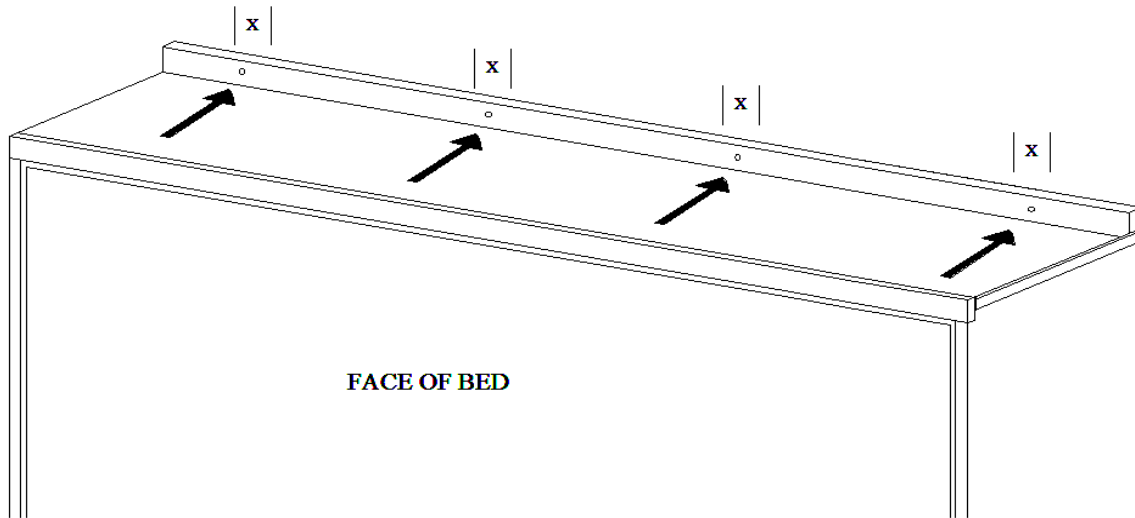

Finally, making sure that the gap around the bed is equal, drive a Black 3" Wood Screw (O) into each predrilled hole and into the wall studs. You may consider different fasteners for different wall types. **MAKE SURE THAT THE SCREWS ARE IN THE STUD AND THAT THE HEADER IS TIGHT TO THE WALL.** You will know you have hit the studs if it's more difficult to turn the screw. If not, you are into the drywall only. You will need to try to locate the studs again. To test this, pull on the Header a few times to make sure it does not come away from the wall.

⚠ WARNING IT IS EXTREMELY IMPORTANT THAT THE BED BE PROPERLY AND SECURELY AFFIXED TO THE WALL. FAILURE TO DO SO CAN CAUSE SERIOUS INJURY OR DEATH!

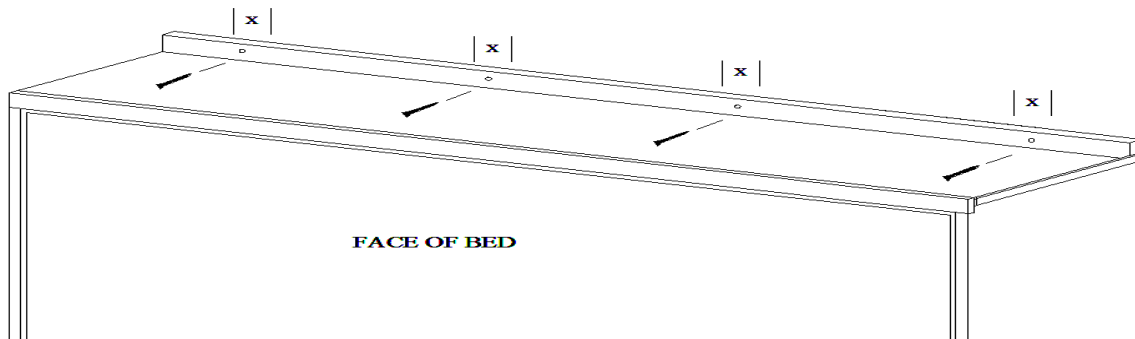

STEP 19: After the wall bed is attached to the wall, use the $\frac{3}{8}$ " Wood Plugs and push them into the $\frac{3}{8}$ " indentation made in **STEP 18**. These plugs are used to hide the mounting screws.

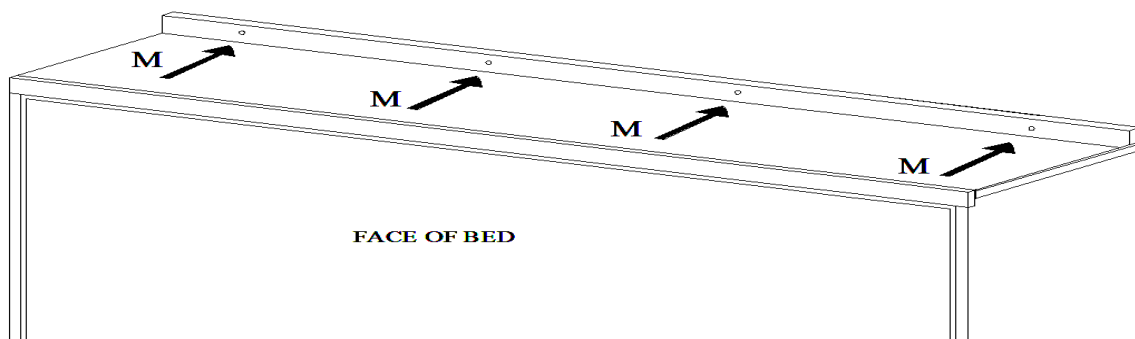

STEP 20: To install your mattress, you must first open the bed. Using the upper most handles (depending on face style), pull the bed down to the open position. The weight of the mattress will hold the bed down; however, one person will need to hold the bed down during this step until the mattress is placed in the face of the bed.

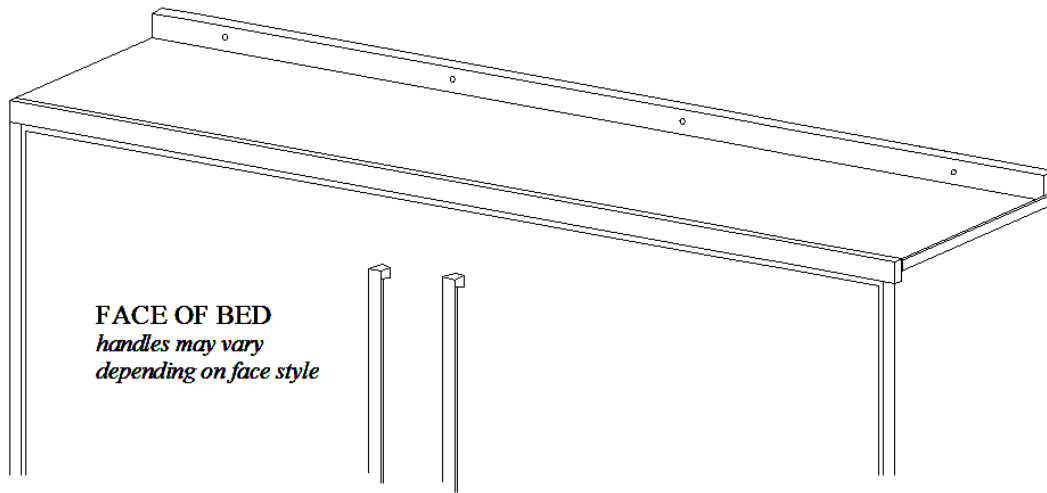

STEP 21: To keep the mattress in place when the bed is closed, simply pull the elastic straps at the bottom of the Assembled Face over the end of the mattress. These straps fit nicely under the fitted sheets and out of plain view.



STEP 22: If you purchased side cabinets, these can be installed once the bed is fastened to the studs in the wall. Push the cabinet against the bed making sure that the top molding and the base molding on the cabinet lines up with the front edge of the bed. Once you are happy with the way the cabinet fits, drive screws from the side cabinet into the Cabinet Vertical of the bed as shown below. Be careful not to drive the screws too far and through the Cabinet Verticals!

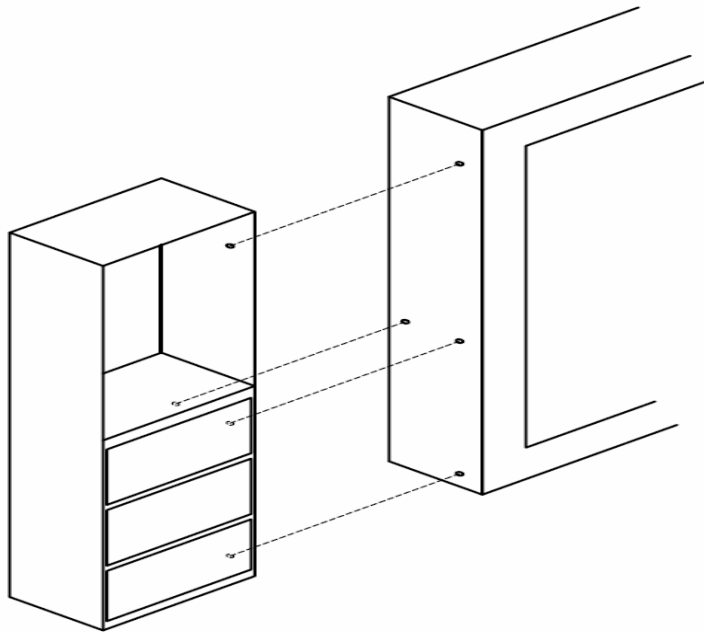

**YOU HAVE SUCCESSFULLY FINISHED THE
INSTALLATION OF YOUR NEW WALL BED!**

CONGRATULATIONS!